

LT180 Quick Setup Guide

NEC

7N8P5551
Printed in China

Copyright© 2005 by NEC Viewtechnology, Ltd.
Ver 1.01/05

Step 1 Connect your video equipment or computer to the projector.

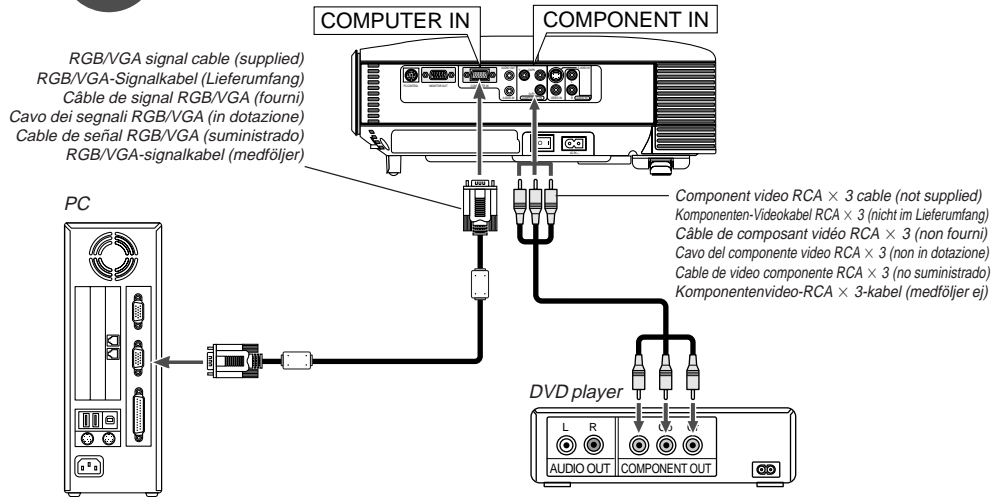

Step 2 Connect the supplied power cable.

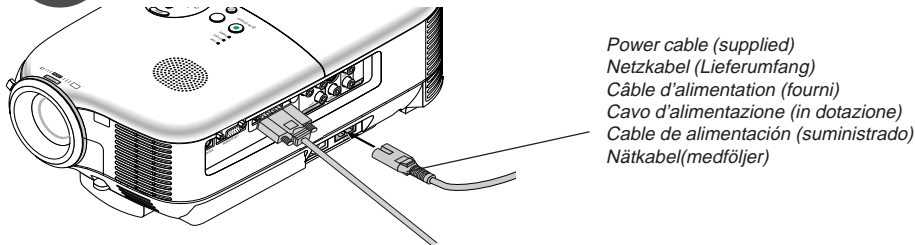

Step 3 Turn on the main power switch.

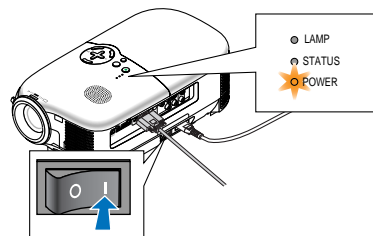

Step 4 Turn on the projector.

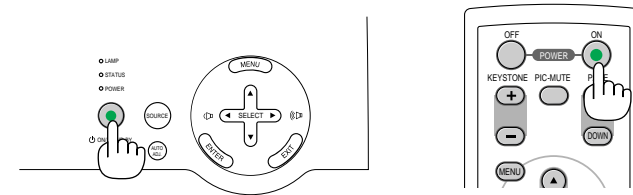

To turn on the projector, press and hold the **ON/STAND BY** button on the projector cabinet or the **POWER ON** button on the remote control for a minimum of 2 seconds.

Drücken und halten Sie zum Einschalten des Projektors die **ON/STAND BY**-Taste am Projektorgehäuse oder die **POWER ON**-Taste auf der Fernbedienung mindestens 2 Sekunden lang gedrückt.

Pour allumer le projecteur, appuyer sur la touche **ON/STAND BY** du coffret du projecteur ou sur la touche **POWER ON** de la télécommande et la maintenir enfoncée pendant au moins 2 secondes.

Per accendere la corrente del proiettore, premete e mantenetelo premuto il tasto **ON/STAND BY** sull'involucro del proiettore o il tasto **POWER ON** del telecomando, mantenendolo premuto per almeno 2 secondi.

Para conectar la alimentación del proyector, pulse el botón **ON/STAND BY** en la cubierta del proyector o el botón **POWER ON** en el mando a distancia durante al menos 2 segundos.

Tryck på **ON/STAND BY**-tangenter på projektorhöljet eller **POWER ON**-tangenter på fjärrkontrollen intryckt i minst 2 sekunder för att slå på strömmen till projektorn.

Step 5 Select a source.

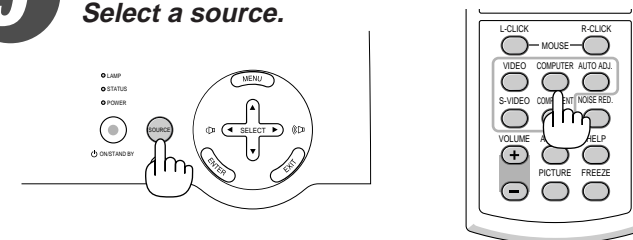

Step 6

Adjust the picture size and position.

• Adjust the tilt foot.

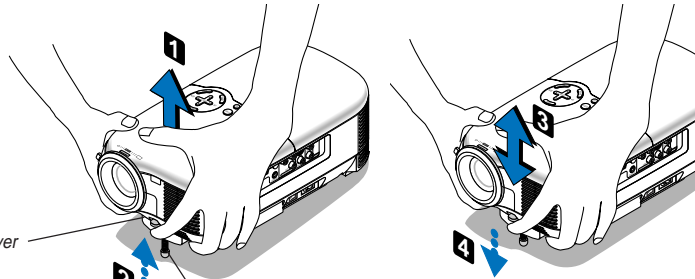

Adjustable Tilt Foot Lever
Kippfuß-Einstellhebel
Lever du pied à inclinaison réglable
Leva del piedino di inclinazione regolabile
Palanca de la pata de inclinación ajustable
Justerfotsspak

Adjustable Tilt Foot
Einstellbarer Kippfuß
Pied à inclinaison réglable
Piedino di inclinazione regolabile
Pata de inclinación ajustable
Justerfot

• Adjust the rear foot.

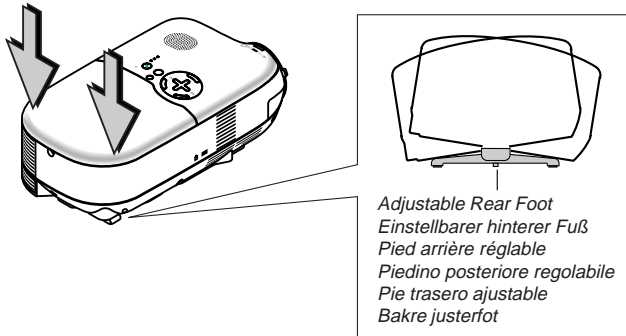

Adjustable Rear Foot
Einstellbarer hinterer Fuß
Pied arrière réglable
Piedino posteriore regolabile
Pie trasero ajustable
Bakre justerfot

• ZOOM

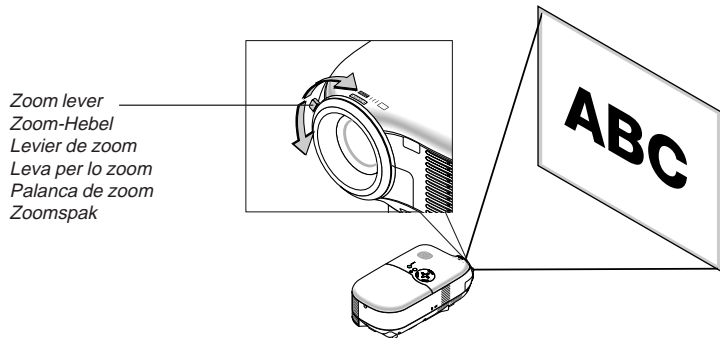

Zoom lever
Zoom-Hebel
Lever de zoom
Leva per lo zoom
Palanca de zoom
Zoomspak

• FOCUS

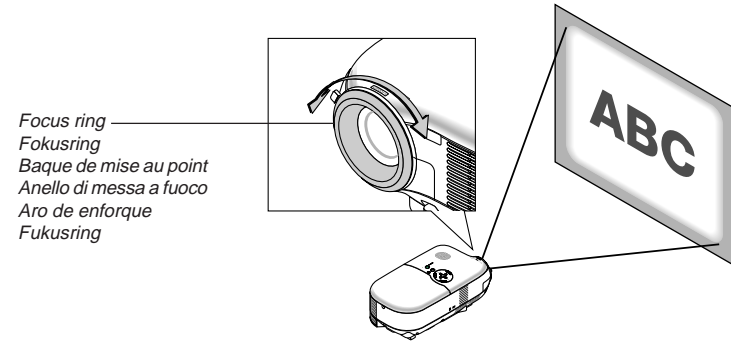

Focus ring
Fokusring
Baque de mise au point
Anello di messa a fuoco
Aro de enforque
Fukusring

• Correct keystone distortion

